

GSTF-A56 Corner Fastener

Features

- Designed to allow front operation
- Available as parallel mount or perpendicular mount
- Suitable for applications such as doors and covers that require for dust proofing, drip proofing or anti vibration

Material

- Stainless steel 304, barrel polished



GSTF-A56AH (Parallel mount type)

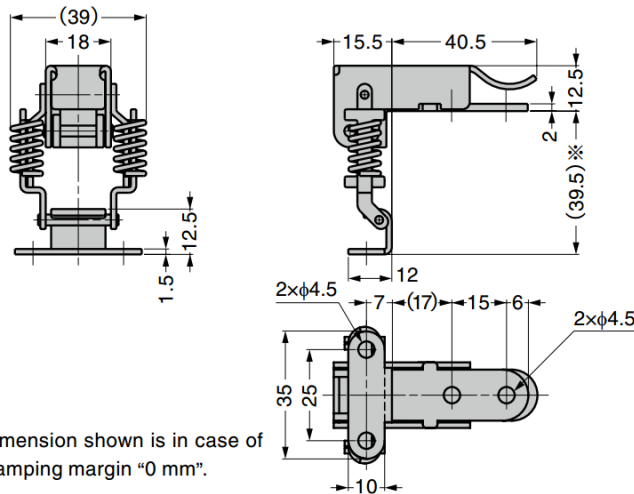

※Dimension shown is in case of clamping margin "0 mm".

Part No.
GSTF-A56AH

GSTF-A56AC (Perpendicular mount type)

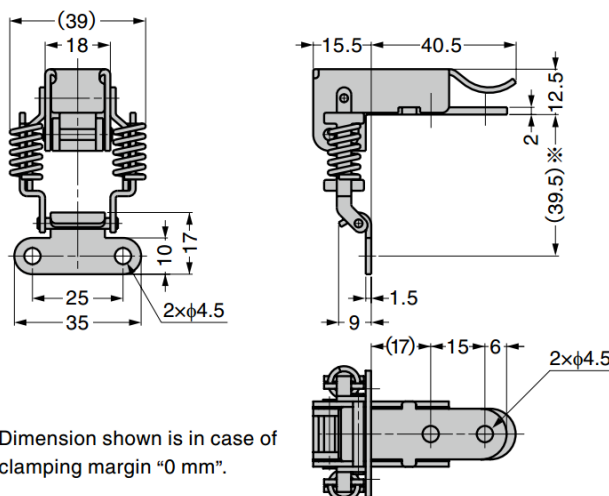

※Dimension shown is in case of clamping margin "0 mm".

Part No.
GSTF-A56AC